

Návod na montáž

Typ EV220B 6, 10 NC/NF - NO/NA EV220B 12, 18, 22 NC/NF

032R9321

NC/NF: EV220B 6, 10, 12, 18, 22

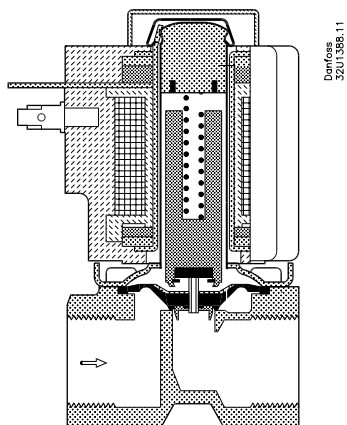

NO/NA: EV220B 6, 10

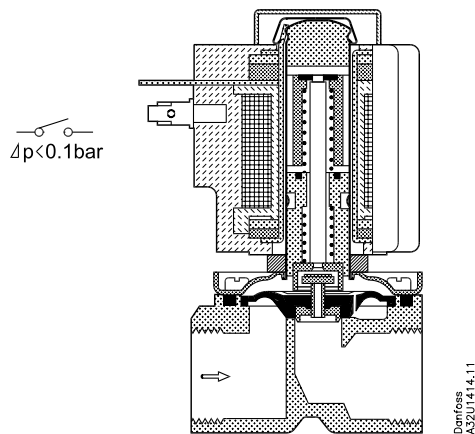

032R9321

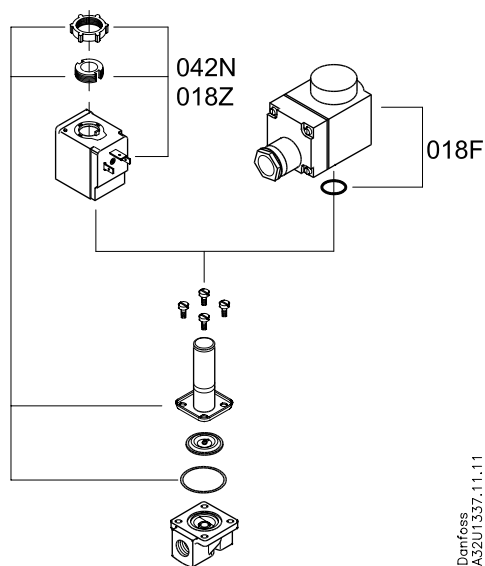
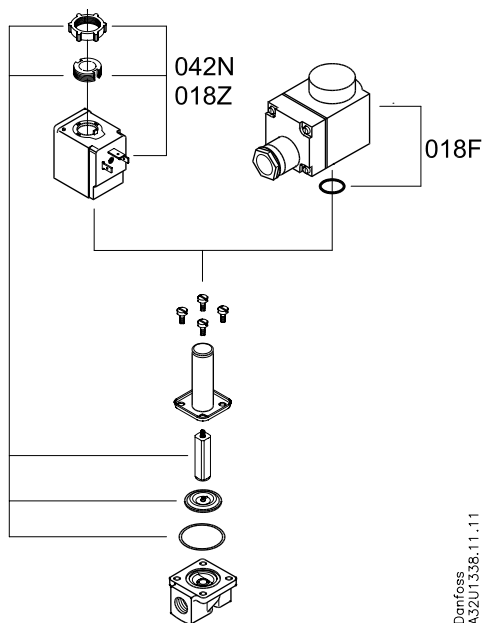

Typ	Objednáací číslo	
	EPDM	FKM
EV220B 6	032U1062	032U1063
UK WRAS	032U6001	
EV220B 10	032U1065	032U1066
UK WRAS	032U6002	
EV220B 12	032U1068	032U1067
UK WRAS	032U6003	
EV220B 18 - 22	032U1070	032U1069
UK WRAS	032U6004	

Typ	Objednáací číslo	
	EPDM	FKM
EV220B 6	032U0165	032U1066
EV220B 10		032U1067

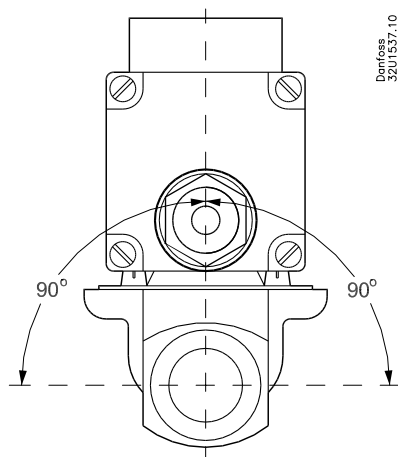

Teplota media T
FKM: 0°C → +100°C
EPDM: -30°C → +100°C
(NC/NF) UK WRAS

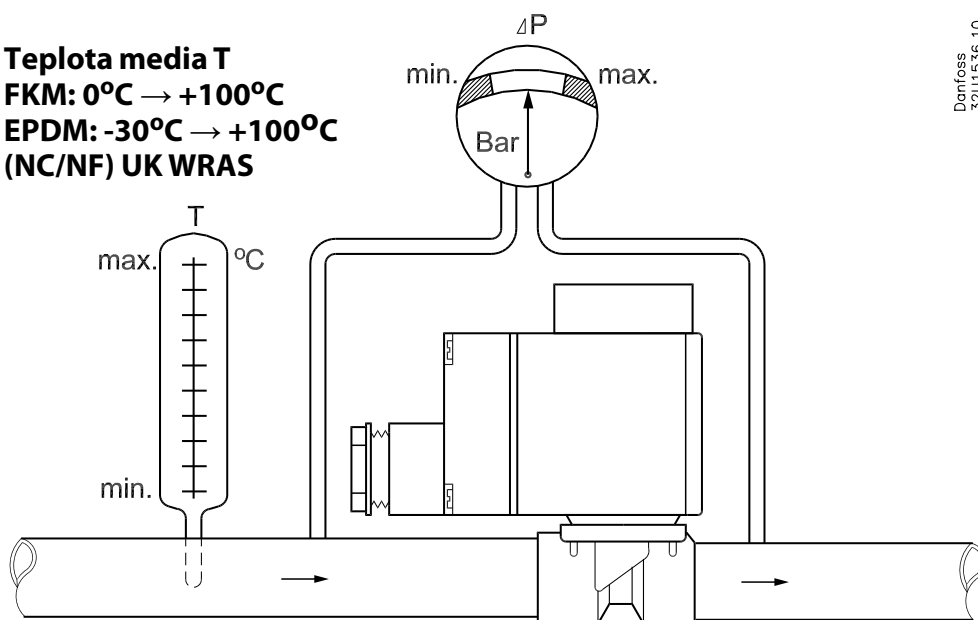

Typ NC/NF	Cívka	9 W AC		10 W AC		15 W DC		18 W DC		20 W DC		10 W AC Ex	
		min.	max.	min.	max.	min.	max.	min.	max.	min.	max.	min.	max.
EV220B 6	FKM	0.1	20	0.1	20	-	-	0.1	10	0.1	20	0.1	10
	EPDM	0.1	20	0.1	20	-	-	0.1	10	0.1	20		
EV220B 10	FKM	0.1	20	0.1	20	-	-	0.1	10	0.1	20	0.1	10
	EPDM	0.1	20	0.1	20	-	-	0.1	10	0.1	20		
EV220B 12-18-22	FKM	0.3	10	0.3	10	-	-	-	-	0.3	10	0.1	10
	EPDM	0.3	10	0.3	10	-	-	-	-	0.3	10		